

TROLLEYS ECONOMICAL VIEW

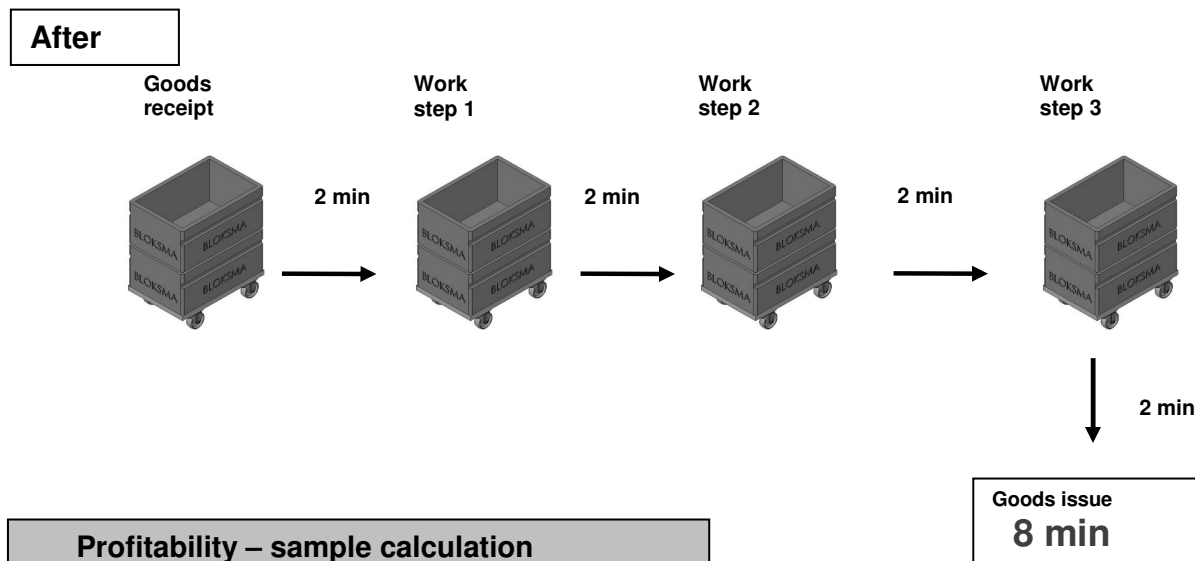
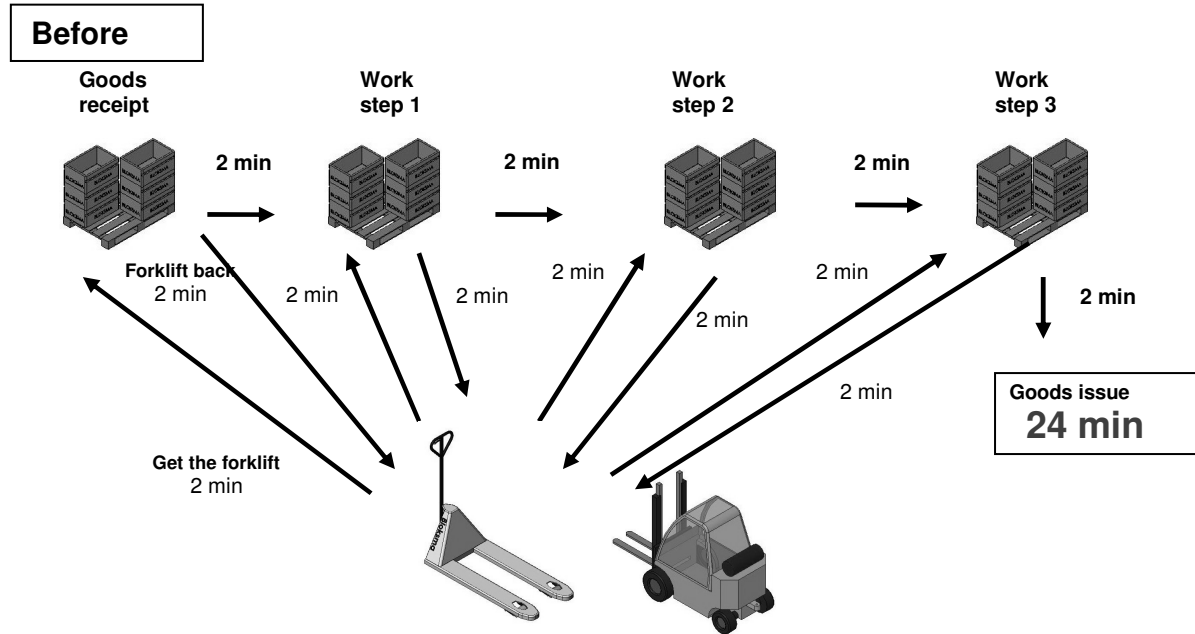

Profitability – sample calculation

working time in minutes		forklift	trolley	saved min
sum of searching and walking ways		24	8	16
x change of pallets per shift	4	96	32	64
x shifts per day	3	288	96	192
x days per year	240	69.120	23.040	46.080

= saved hours	768
---------------	-----

x your wage hour rate	€
x your machine hour rate	€
savings	€

Further savings: no investments for floor borne vehicles (as for example forklifts) and their maintenance