

CHECKLIST LIFTERS

Features of the lifters

Impulse	<input type="checkbox"/> Electric	<input type="text" value=""/>	Volt	<input type="checkbox"/> Pneumatic	<input type="text" value=""/>	bar
Model	<input type="checkbox"/> Mobile			<input type="checkbox"/> Semi-mobile	<input type="checkbox"/> Stationary	
Loading type	<input type="checkbox"/> Front loading			<input type="checkbox"/> Side loading left	<input type="checkbox"/> Side loading right	
	<input type="checkbox"/> Gemini			<input type="checkbox"/> Tandem	<input type="checkbox"/> Drive through	
Position of the trolley	<input type="checkbox"/> lengthwise			<input type="checkbox"/> crosswise		
Capacity	<input type="text" value=""/>		kg			
Working height above floor level (GOK)	<input type="checkbox"/> 720 mm			<input type="checkbox"/> 920 mm	<input type="checkbox"/>	Define your needed size
Operating element	<input type="checkbox"/> Hand lever			<input type="checkbox"/> Push button		
	<input type="checkbox"/> Foot switch			<input type="checkbox"/> Panel		
Additional functions	<input type="checkbox"/>	Automatic mode with sensor (which loaded item shall give the impulse (KLT / Wire basket or etc.))		<input type="checkbox"/> Trolley load control	<input type="checkbox"/> Panel holder	
	<input type="checkbox"/> Protection mat			<input type="checkbox"/> Protection wall		
ESD ability	<input type="checkbox"/> YES			<input type="checkbox"/> NO		
Colour	<input type="checkbox"/> Standard pneumatic white - RAL 9010			<input type="checkbox"/> Standard electric white / magenta - RAL 9010/RAL 4006		

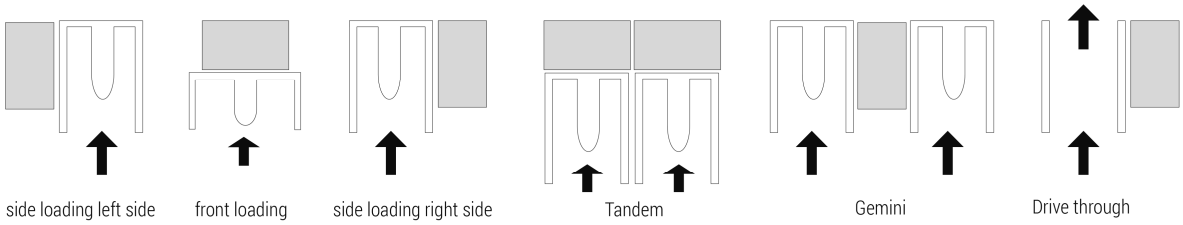

Features of the trolley

Item No. / Brand	<input type="text" value=""/>	
Length	<input type="text" value=""/>	mm
Width	<input type="text" value=""/>	mm
SPW in direction of entry	<input type="text" value=""/>	mm
Distance clearance	<input type="text" value=""/>	mm
Wheel diameter	<input type="text" value=""/>	mm
Wheel width	<input type="text" value=""/>	mm
Brake	<input type="checkbox"/> YES	<input type="checkbox"/> NO
Wheel pairing	<input type="checkbox"/> 2 swivel / 2 fixed castors	<input type="checkbox"/> 4 swivel castors

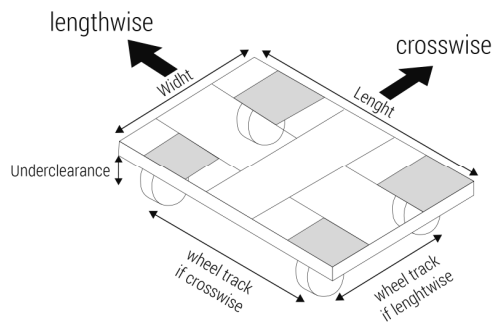

Additional comments (e.g. disturbing elements at the bottom of the trolley)

	<input type="text" value=""/>
	<input type="text" value=""/>
	<input type="text" value=""/>

POSSIBLE APPLICATIONS / SET-UP FOR LIFTERS

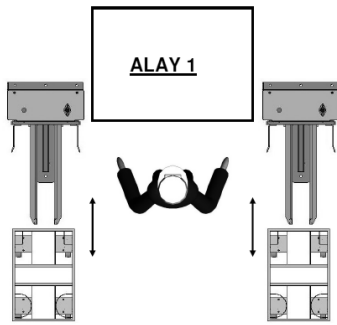

Front loading

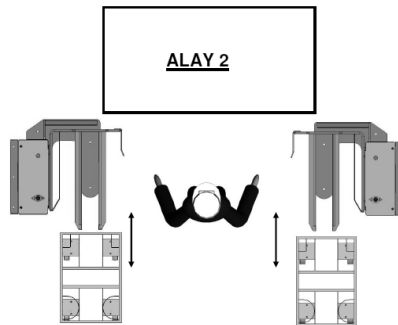

Left Sideloading Right

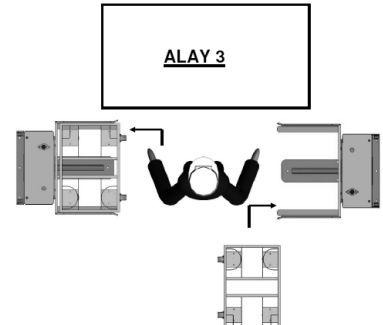

Front loading

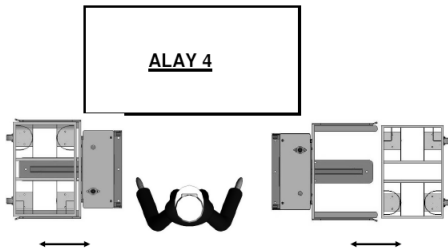

Front loading

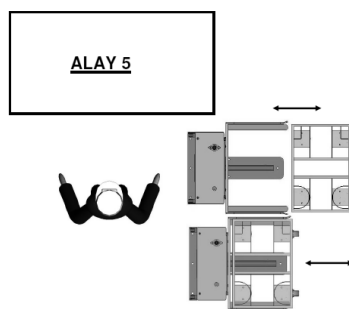

Front loading

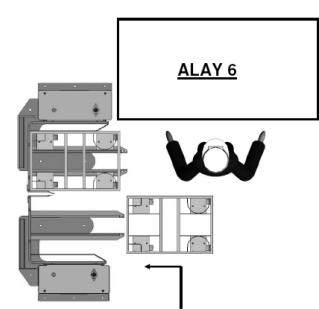

Sideloading Left and Right

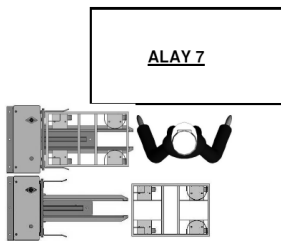

Front loading

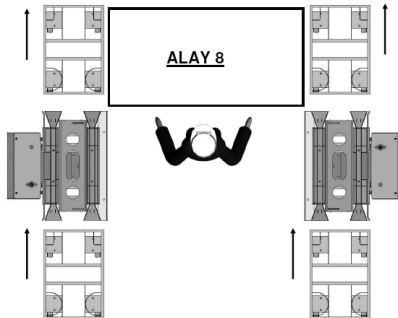

Drive through

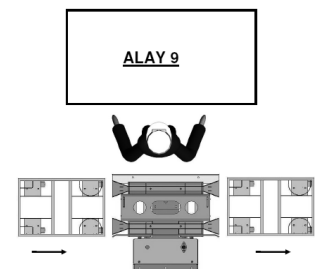

Drive through

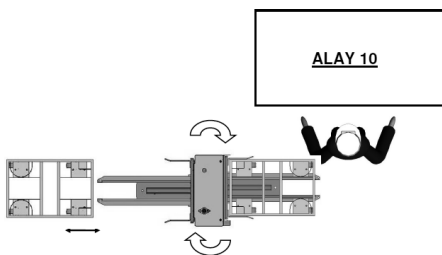

Turnable

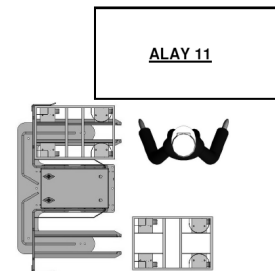

Gemini

POSSIBLE APPLICATIONS / LAYOUT OF WORKPLACE – ALAY

ALAY	1	2	3	4	5	6	7	8	9	10	11
Front loading	●		●	●	●		●	●	●	●	●
Side loading		●				●					
Stationary	●	●	●	●	●	●	●	●	●	●	●
Semi-mobile	●	●	●	●	●	●	●	●	●		
Mobile	●	●	●	●	●	●	●	●	●		
Side Tandem / Twin lifter						●	●				●
Removal from rear / back side				●	●						
Driving through possible								●	●		
Swivelling in working area										●	●
Replacement by system provider	●	●		●	●			●	●	●	●

Front loading

Side loading

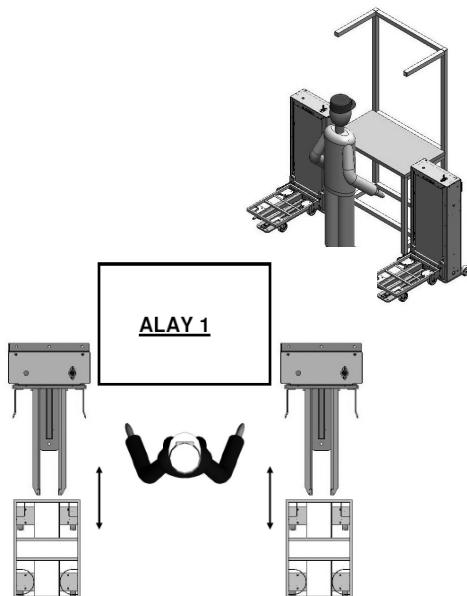

Front loading

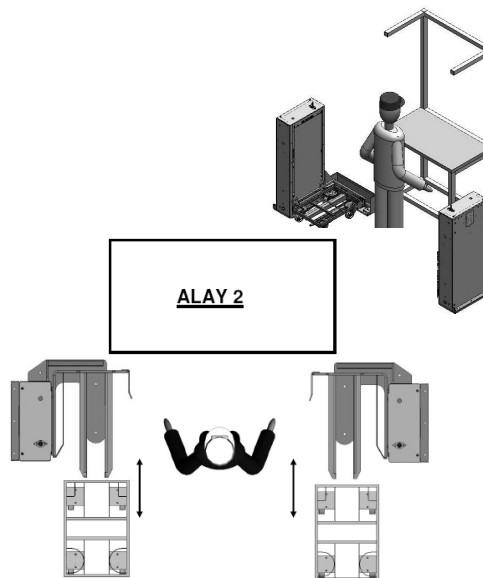

Side loading left

Side loading right