

TRANSPORT LOGISTICS MILKRUN

Platform Taxi Carts TRP II

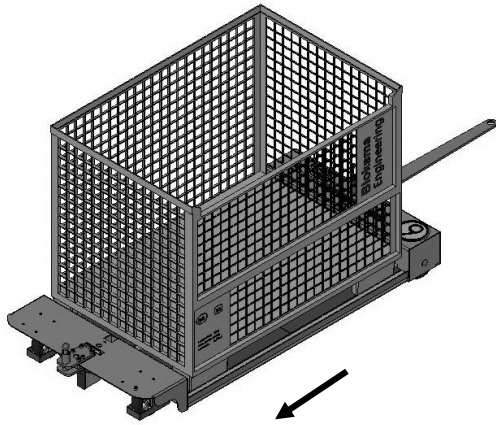

Item no. 13319

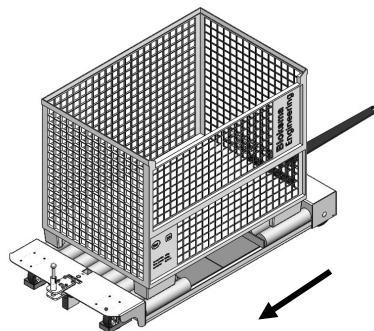

Item no. 201855

For fast and safe indoor transport of containers.

The containers are moved onto resp. removed from the taxi cart by means of forklift trucks / electric pallet trucks or other industrial trucks.

Drawbars adapted to your tractor.

Steering system: trailing steering system

Max. load 500 kg

Designed for indoor transport only

Various versions available (housing, colours, etc.)

Item no.	Product to be transported	Remark	Features of wheels	Trolley with
133191	pallet cage or pallet size 1.200 x 800 mm		Ø 200 mm Polyurethan	2 swivel and 2 fixed castors
136995	pallet cage or pallet size 1.200 x 800 mm		Ø 200 mm Polyurethan	2 swivel and 2 fixed castors

201855-0800	pallet cage or pallet size 1.200 x 800 mm	with roller track	Ø 200 mm Polyurethan	2 swivel and 2 fixed castors
201855-1000	pallet cage or pallet size 1.200 x 800 mm	with roller track	Ø 200 mm Polyurethan	2 swivel and 2 fixed castors

Other models / dimensions on request.