

TRANSPORT LOGISTICS MILKRUN

Shelf Carts TRR

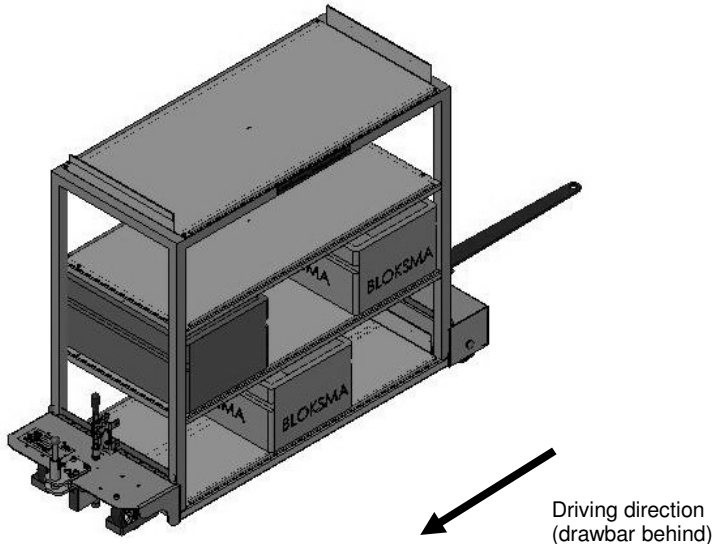

Item no. 143102

For fast and safe indoor transport of boxes

The boxes/bins are manually placed onto respectively removed from the shelves

Drawbar adapted to your tractor

Steering system: trailing steering system

Available in various designs (steel, tubular or aluminium profile system)

Max. load 350 kg

For indoor transport only

Various designs available (housing, colours, etc.)

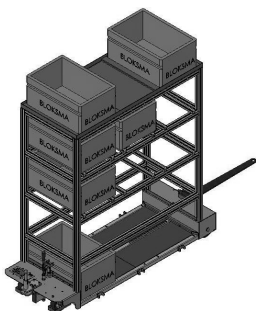

Item no. 202673

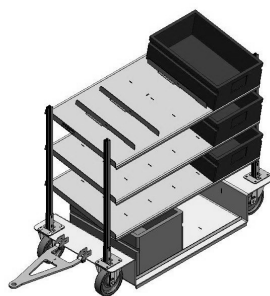

Item no. 136240

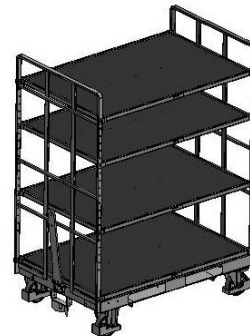

Item no. 202674

Item no.	Product to be transported	Features of wheels	Trolley with
143102	KLT 600 x 400 mm up to 12 units	Ø 125 mm Polyurethan	2 swivel and 2 fixed castors
202673	KLT 600 x 400 mm up to 15 units	Ø 125 mm Polyurethan	2 swivel and 2 fixed castors
136240	KLT 600 x 400 mm up to 11 units partly with inclined shelf	Ø 200 mm Polyurethan	2 swivel and 2 fixed castors
202674	KLT 600 x 400 mm oder 800 x 600 mm up to 16 units	Ø 150 mm Polyurethan	2 swivel and 2 fixed castors

Other models / dimensions on request.

TRANSPORT LOGISTICS

Transport Carts TRW

For fast and safe indoor transport of boxes or products

Manual loading and unloading of boxes / products

Mostly manual transport

Various designs available (housing, colours, etc.)

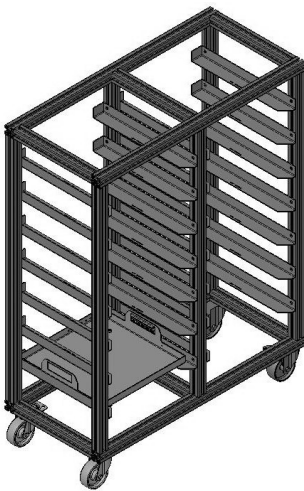

Item no. 130052

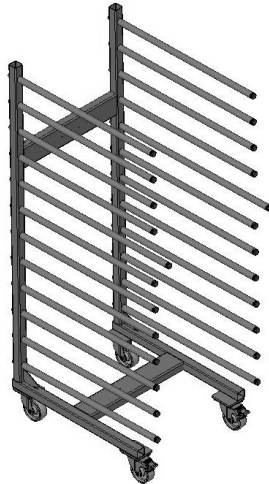

Item no. 138869

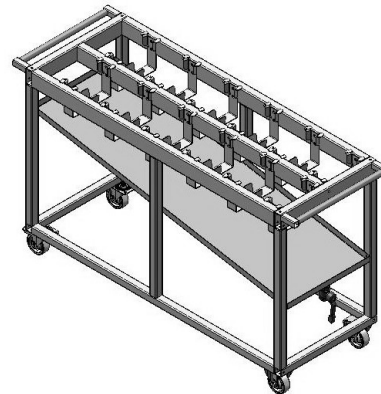

Item no. 132330

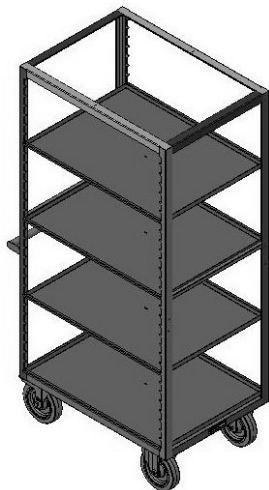

Item no. 142824

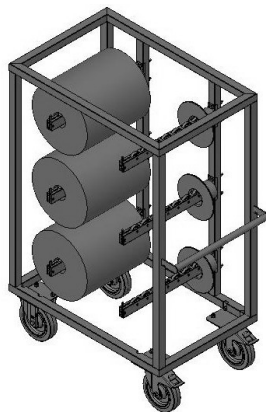

Item no. 142823

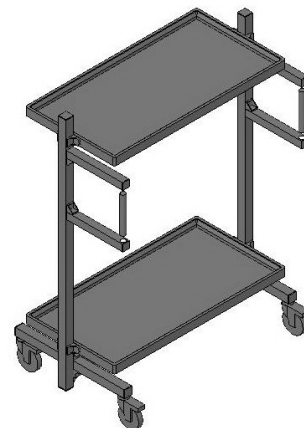

Item no. 139663

Other models / dimensions on request.